

# DTV TRANSMISSION RF MEASUREMENTS

## EMISSION MASK COMPLIANCE

Greg Best Consulting, Inc.

May 4th, 2007

# Introduction

- ◆ Important that when the transmission system is placed in service it meets FCC compliance
  - Transmission system up to the antenna
- ◆ Important as new transmitters are added to the site that all new systems meet FCC compliance
- ◆ With DTV more stations can be packed into a given amount of spectrum-
  - Co-located adjacent channel situations more common
- ◆ Emission Characteristics
  - Power measurement
  - Frequency Measurement
  - Emission mask
- ◆ Discuss test equipment needs and features

# Introduction

- ◆ STL
- ◆ Main Transmitter

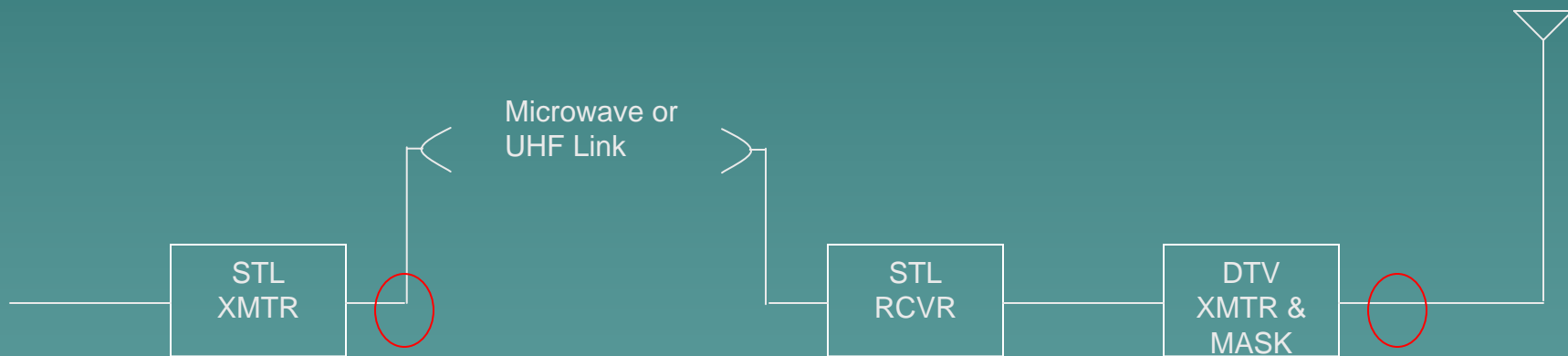

# DTV TRANSMISSION SYSTEM

- ◆ What do I have to measure and how often do I have to/should I measure it??
- ◆ What are typical problems?
  - Unstable RF power
  - Frequency stability
  - Input Signal stability
    - ◆ No Impact on emission unless a heterodyne translator is used

# DTV Transmitter

When was the last time it was checked for power, frequency, and emission mask?

# DTV Transmitter Emission Mask Compliance

- ◆ FCC Rules 74.796 (a) (2) & (3) and 73.622 (h) (1) & (2)
- ◆ FCC Public Notice DA 05-1321 issued on May 10, 2005
- ◆ IEEE Emission Mask Compliance Recommended Practice (In Process)

# Emission Mask Compliance

- ◆ VHF or UHF Channel--6 MHz authorized BW

## 8-VSB Stringent Mask Emission Limits

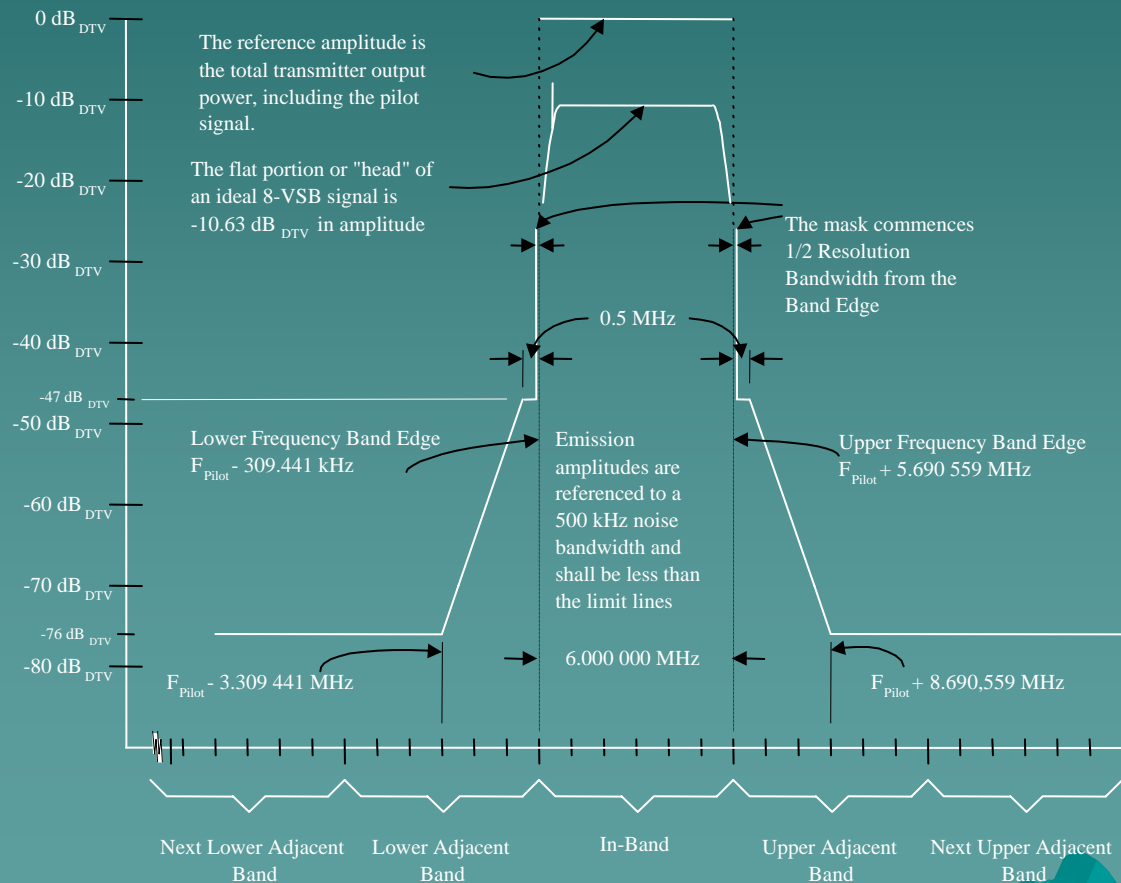

# DTV Transmitter Emission Mask Compliance

## Areas of Interest

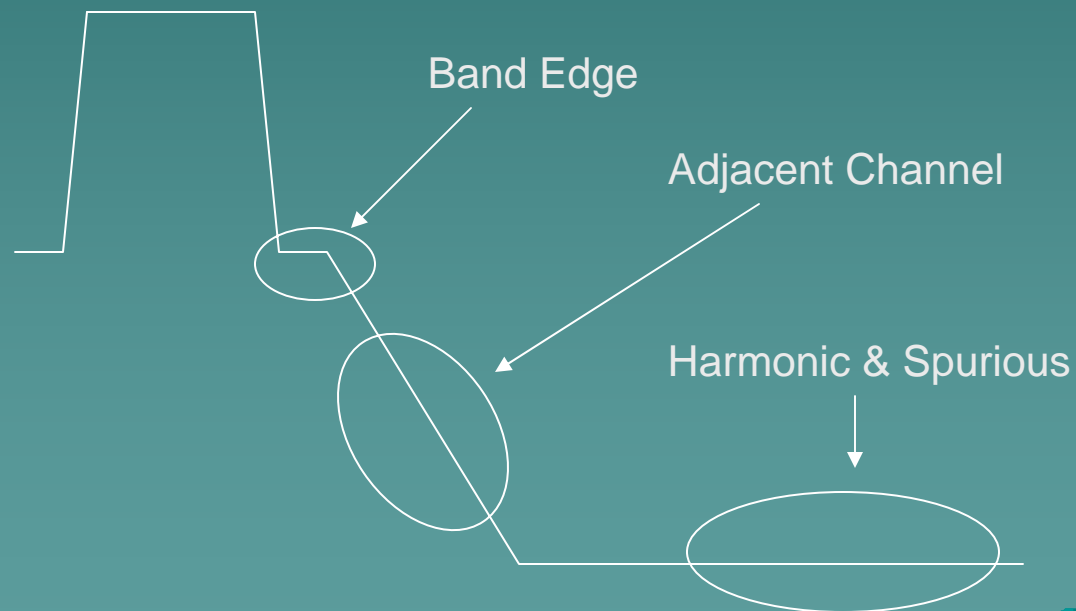

# IEEE Recommended Practice Adjacent Channel Measurement Method

- ◆ Design the test
  - Operate xmtr into a load if possible
- ◆ Need to have
  - Spectrum Analyzer—modest performance
  - RF sample
  - Band-Stop filter

# IEEE Recommended Practice Adjacent Channel Measurement Method

- ◆ Design the test--Need to know
  - Analyzer Noise Floor in specific RBW
  - Is RF sample the “right” size
  - Amplitude versus Frequency Response of Band-Stop filter over 3 channels
    - ◆ Characterize before measuring xmtr

# IEEE Recommended Practice Adjacent Channel Measurement Method

- ◆ Block diagram of emission mask compliance test

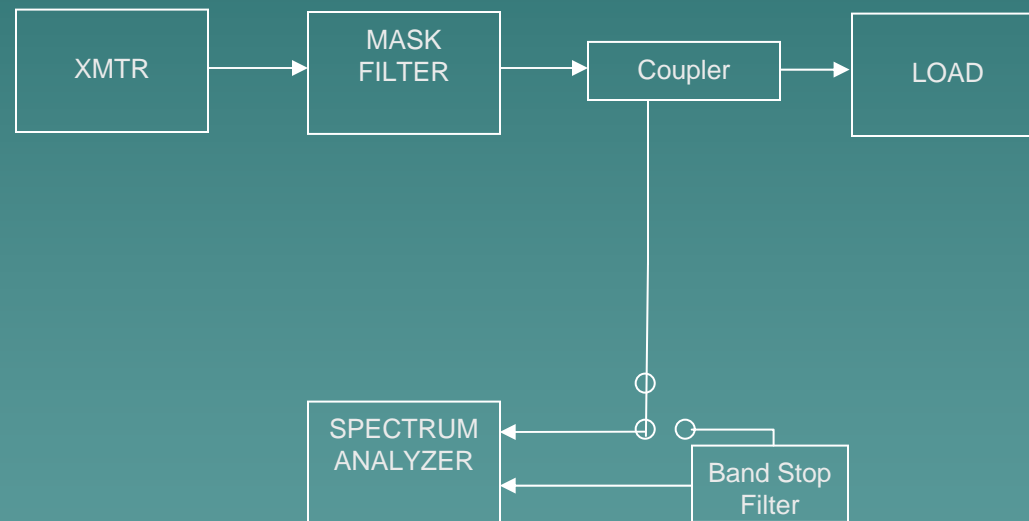

# IEEE Recommended Practice Adjacent Channel Measurement Method

- ◆ Determine if RF sample is the “right” size
  - Too Large--damages the spectrum analyzer
  - Too small—cannot measure to mask limits
- ◆ Typical signal levels required
  - Full Service +27 dBm
  - Stringent -7 dBm
  - Simple -2 dBm

# IEEE Recommended Practice Adjacent Channel Measurement Method

- Most spectrum analyzers don't have enough dynamic range to measure entire adjacent channel

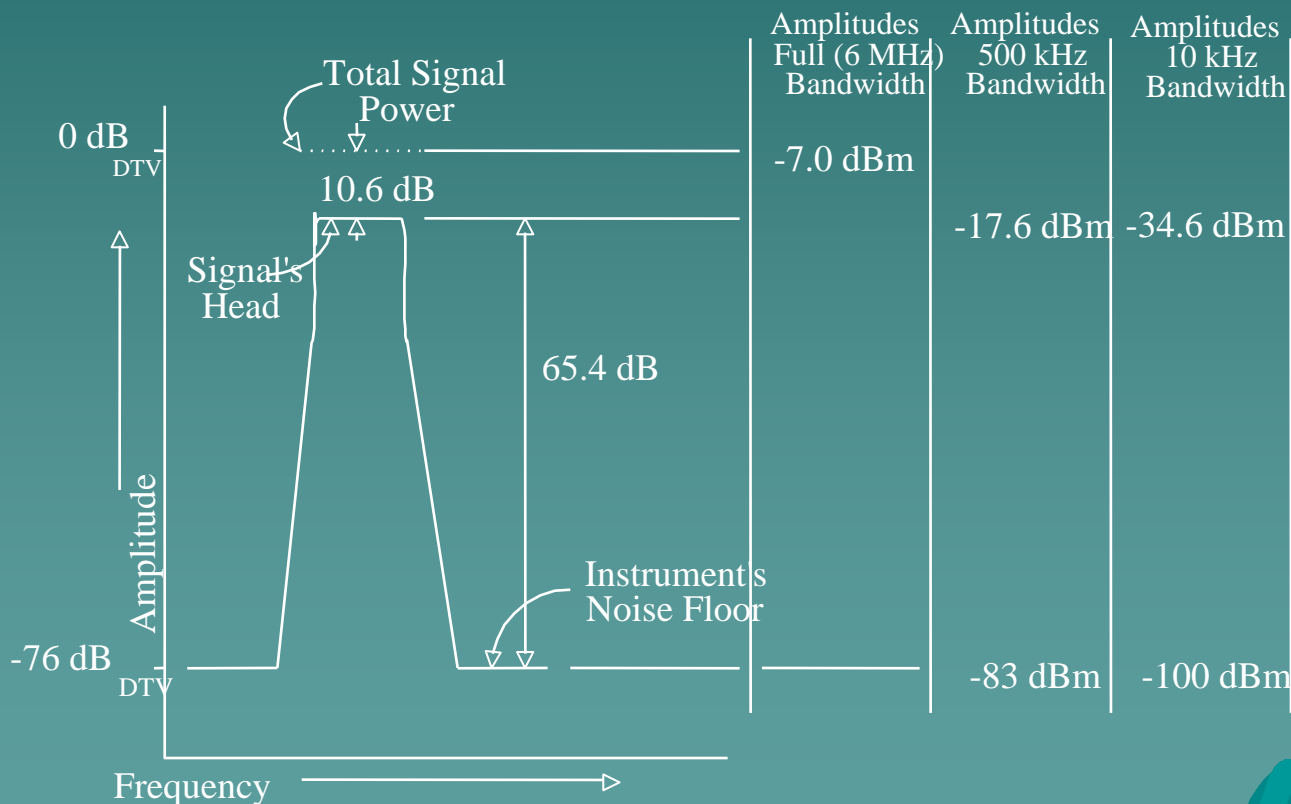

# IEEE Recommended Practice Adjacent Channel Measurement Method

- ◆ Determine minimum RF sample necessary
  - Noise Floor of SA + 76 dB (Stringent) or 71 dB (Simple)
- ◆ Measure desired channel power for reference
  - Number of data points may limit your spectrum analyzer span (Span = max number of data points X RBW)
  - Use 10 kHz RBW-- Wider RBWs add power from the desired channel and contribute errors
  - Use RMS Detection mode specified by manufacturer
  - Video BW set to 3X (Min) of RBW and averaging set for a convenient trade off between sweep refreshing and variation in the measured value

# IEEE Recommended Practice Adjacent Channel Measurement Method

- ◆ Apply the DTV signal to the spectrum analyzer
- ◆ Optimize the spectrum analyzer dynamic range
  - Determining spectrum analyzer “sweet spot” is the trick
- ◆ Measure first 4 subbands in each adjacent channel or until you hit the noise floor after “sweet spot” is found
- ◆ Remove noise floor effects if necessary
  - Typically if measured signal is 7 dB above noise floor, no compensation is necessary

# IEEE Recommended Practice Adjacent Channel Measurement Method

- ◆ How to optimize the spectrum analyzer attenuator setting

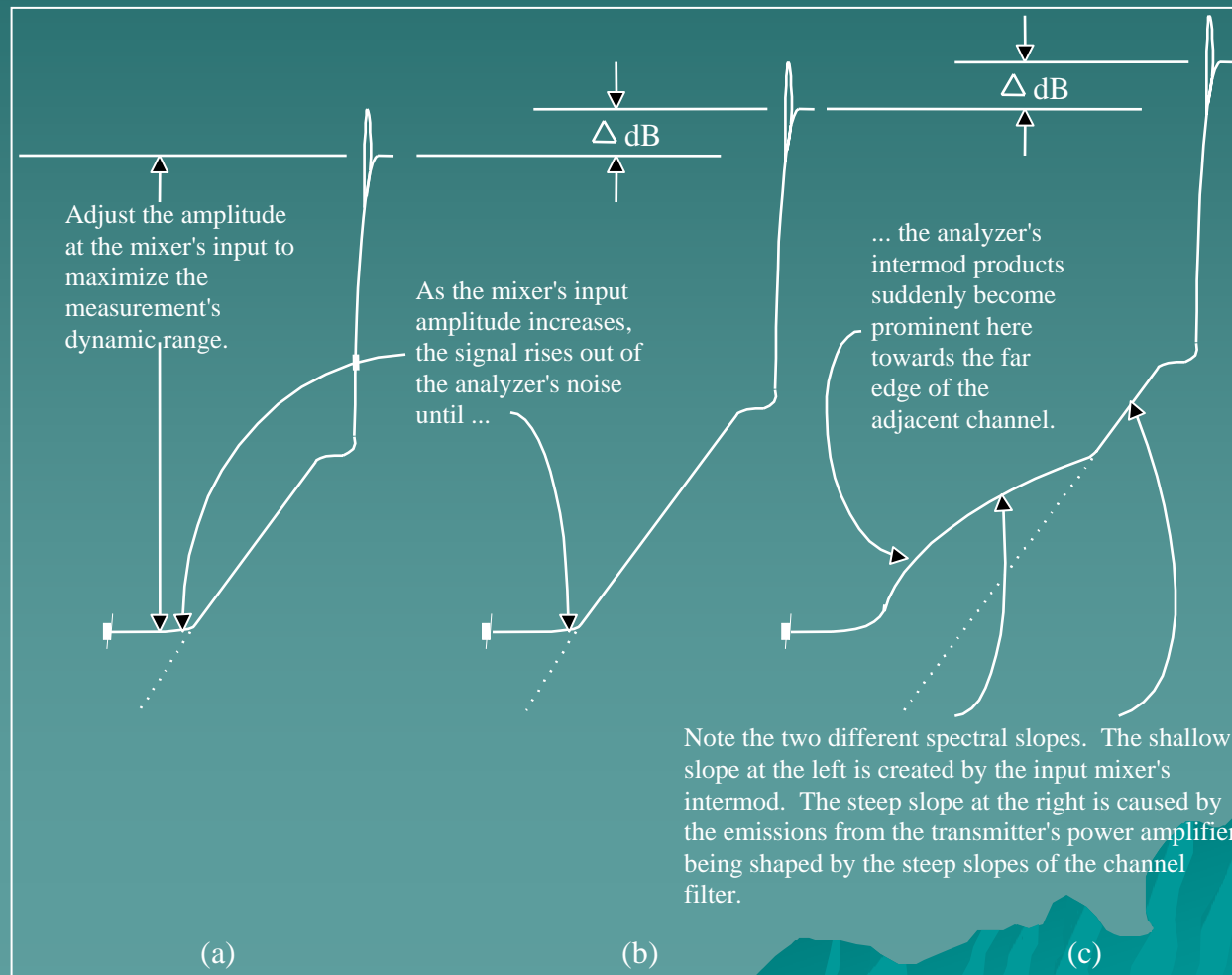

# IEEE Recommended Practice Adjacent Channel Measurement Method

- ◆ Now insert band-stop filter to attenuate the desired channel signal to prevent analyzer overload

# IEEE Recommended Practice Adjacent Channel Measurement Method

## ◆ Effect of the stop-band filter

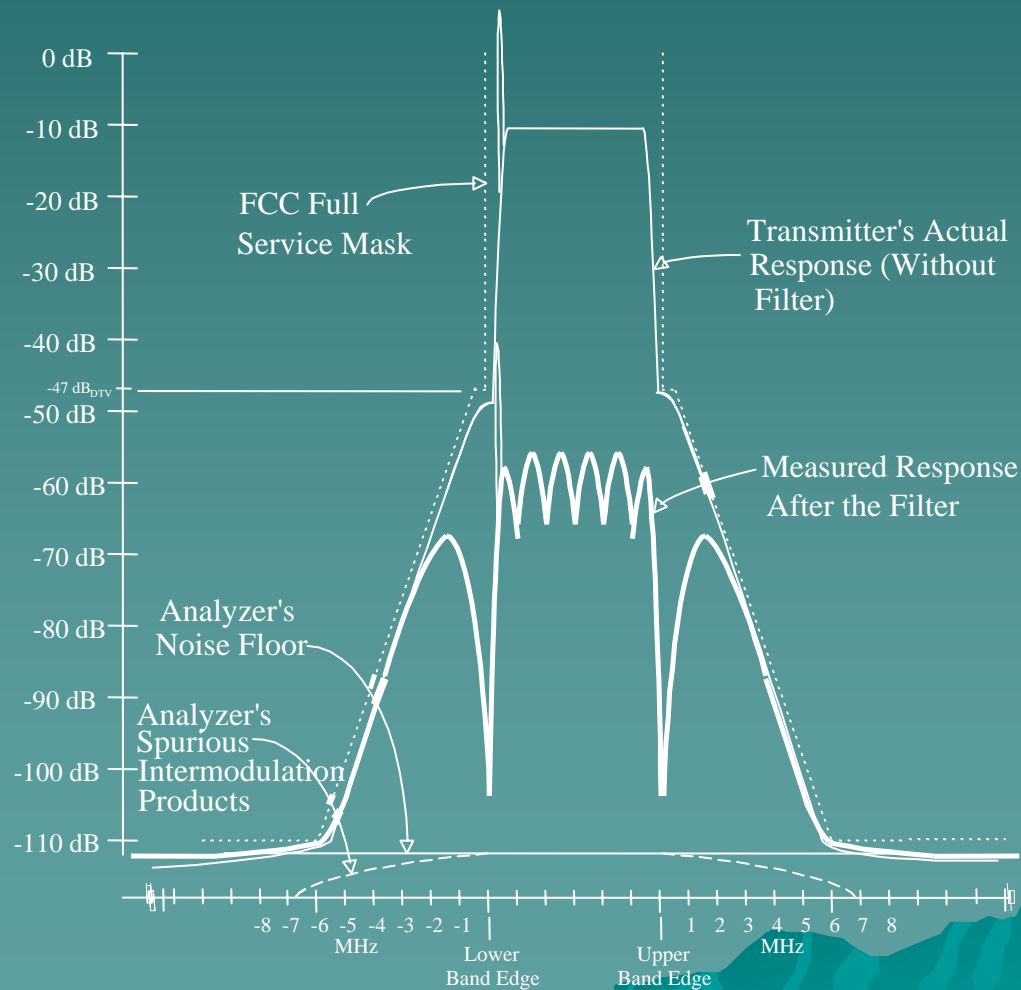

# IEEE Recommended Practice Adjacent Channel Measurement Method

- ◆ Remove attenuation (increase sensitivity) and continue with the measuring each 500 kHz segment in the adjacent channel
- ◆ Factor in stop-band filter loss and noise floor
- ◆ Subtract result from total average power
- ◆ Result must be less than FCC mask

# IEEE Recommended Practice Adjacent Channel Measurement Method

- ◆ Example
- ◆ Design the test
  - Assume that our expected RF sample power is -6 dBm and the spectrum analyzer maximum input level is +30 dBm and the 10 kHz RBW noise floor is -103 dBm
  - Minimum RF sample level needs to be
    - ◆ Analyzer noise floor scaled for 500 kHz +76 dB
    - ◆  $= -103 \text{ dBm} + 17 \text{ dB} + 76 \text{ dB} = -10 \text{ dBm}$
  - Characterized the amplitude versus frequency response of band-stop filter
    - ◆ This should be done each time the procedure is executed to take into account any shift due to temperature or mechanical bumps

# IEEE Recommended Practice Adjacent Channel Measurement Method

- ◆ Assume we have measured the first 4 subbands on either side of the channel and have corrected those values for the noise floor.
- ◆ Now we insert the band-stop filter and remove all the remaining RF attenuation and some IF attenuation of the spectrum analyzer and we measure the #7 subband using 500 kHz channel power measurement mode as -82 dBm and that the band-stop filter at the #7 subband frequency has an loss of 1.0 dB

# IEEE Recommended Practice Adjacent Channel Measurement Method

- ◆ Now we subtract the power of the noise floor and add the insertion loss of the filter.  
$$-82 \text{ dBm} - 86 \text{ dBm} = 6.31 \times 10^{-9} - 2.51 \times 10^{-9} = 3.8 \times 10^{-9} \text{ or } -84.2 \text{ dBm}$$
$$-84.2 \text{ dBm} + 1.0 \text{ dB} = -83.2 \text{ dBm}$$
- ◆ Now we compare this with the channel power reference to obtain a  $\text{dB}_{\text{DTV}}$  value and compare with the emission mask requirement  
$$-6 \text{ dBm} - (-83.2 \text{ dBm}) = 77.2 \text{ dB}_{\text{DTV}}$$

Emission mask at #7 subband must be  $76 \text{ dB}_{\text{DTV}}$
- ◆ Conclusion---This meets the emission mask.

# Practical Measurement Method

## Harmonics

- ◆ Question-What do I measure and what do I compare it to and what bandwidth do I use??
- ◆ Start with channel power again as the reference
- ◆ Insert HPF and increase sensitivity to ensure if signal of FCC limit was present, it would be on screen.
- ◆ Pick worst case 500 kHz channel segment at each harmonic or spurious and compare to total transmitter power.
- ◆ Ensure measurement capability of 2<sup>nd</sup>, 3<sup>rd</sup>, maybe 4<sup>th</sup>.
- ◆ Unless your coupler is calibrated at each harmonic, your readings will not be accurate.
- ◆ Measure to 1.61 GHz (GPS bands) or to 10th harmonic of mid-channel frequency whichever is greater
- ◆ IEEE RF Standards committee is putting together a procedure that should address Part 74 and Part 73 measurement issues and will be added to the Recommended Practice for Emission Mask Compliance

# Practical Measurement Method Harmonics & Spurious

## ◆ Block diagram of measurement

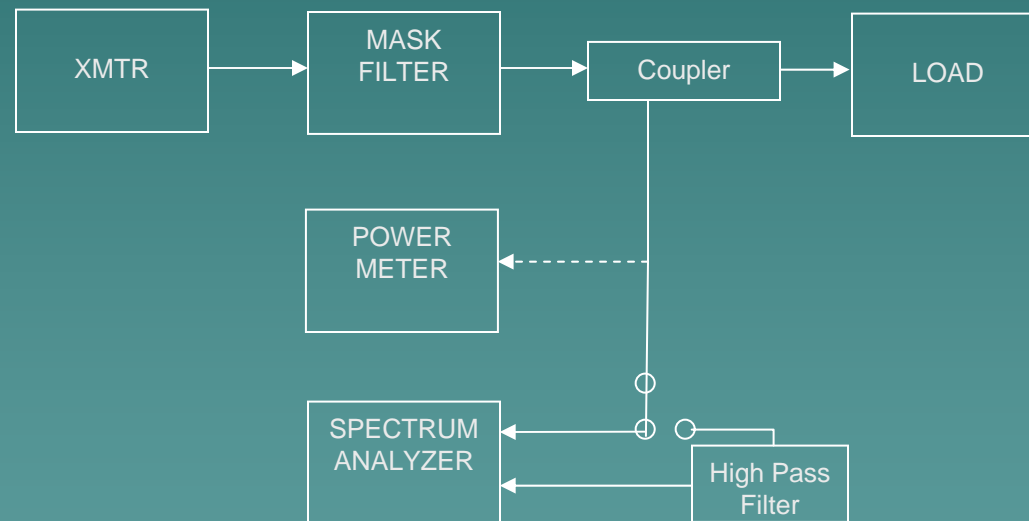

# Practical Measurement Method Harmonics & Spurious

- ◆ Setup spectrum analyzer
  - Set Reference on SA at +30 dBm, 10 kHz RBW
  - RF sample = +7 dBm (measured in 6 MHz channel)
- ◆ Insert HPF with at least 50 dB attenuation
- ◆ Decrease RF attenuation 50 dB (max amount)
- ◆ New SA Reference is at -20 dBm
- ◆ Find noise floor at -105 dBm by removing RF sample
- ◆ Assume we see 2<sup>nd</sup> harmonic energy at -95 dBm
- ◆ Engage channel power mode for 500 kHz
  - Pick the largest signal area
- ◆ Measure channel power of -80 dBm
- ◆ Harmonic power =  $7 - (-80) = -87 \text{ dB}_{\text{DTV}}$

# Test Equipment

- ◆ Spectrum Analyzer
  - Channel Power Measurement Mode
  - Built-in freq counter to get freq measurement
  - Noise floor  $\sim -100$  dBm (10 kHz RBW)
  - 5 dB attenuator step or use external attenuators
    - Needed to optimize “sweet spot” for emission mask compliance

# STL Emission Mask Compliance

- ◆ NTSC was essentially an occupied bandwidth measurement with a given waveform
- ◆ Digital—No change in bandwidth with input or no input signal
- ◆ Displayed signal is a “Noise-Like” signal so amplitude appears to change with RBW
- ◆ QAM, 8-VSB, OFDM
- ◆ Measure with spectrum analyzer using channel power measurement mode

# STL Emission Mask Compliance

- ◆ See FCC rule 74.637
- ◆ Microwave Analog

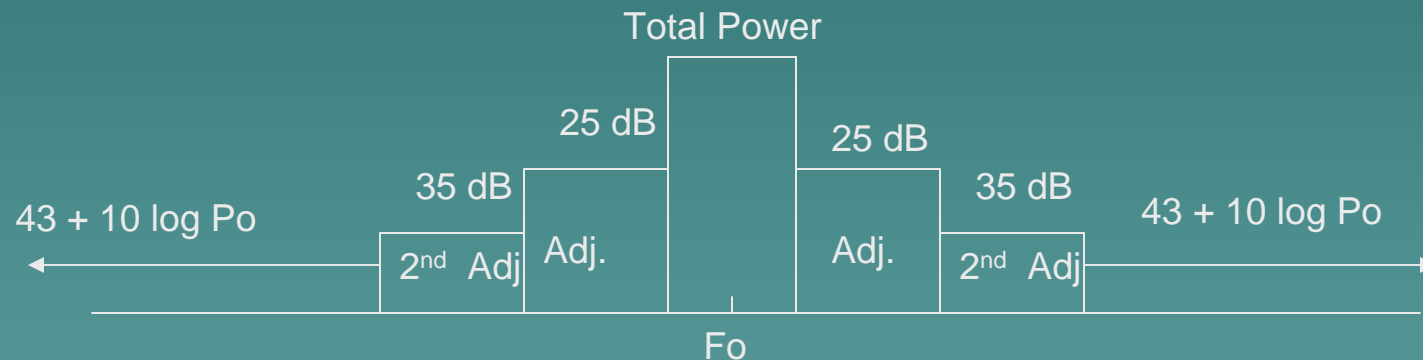

- ◆ Measure in 100 kHz BW
- ◆  $P_o$  = Total average power in 25 MHz

# STL Emission Mask Compliance

- ◆ Digital Microwave--25 MHz authorized BW, for  $F_o < 15$  GHz

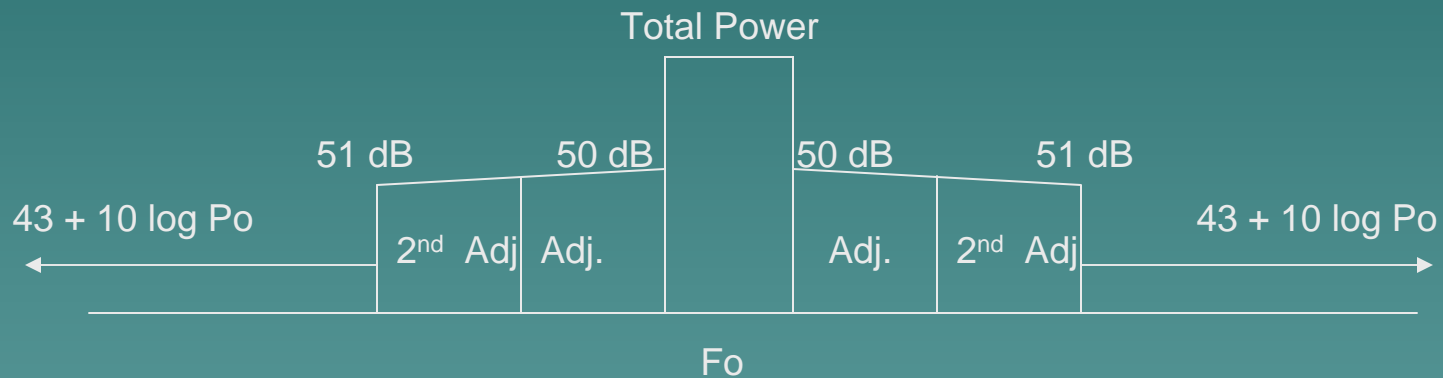

- ◆  $43 + 10 \log P_o$  or 80 dB maximum beyond 2<sup>nd</sup> Adjacent
- ◆ Measured in 4 kHz BW

# STL Emission Mask Compliance

- ◆ UHF Channel--6 MHz authorized BW
- ◆ Same emission mask as LPTV

## 8-VSB Stringent Mask Emission Limits

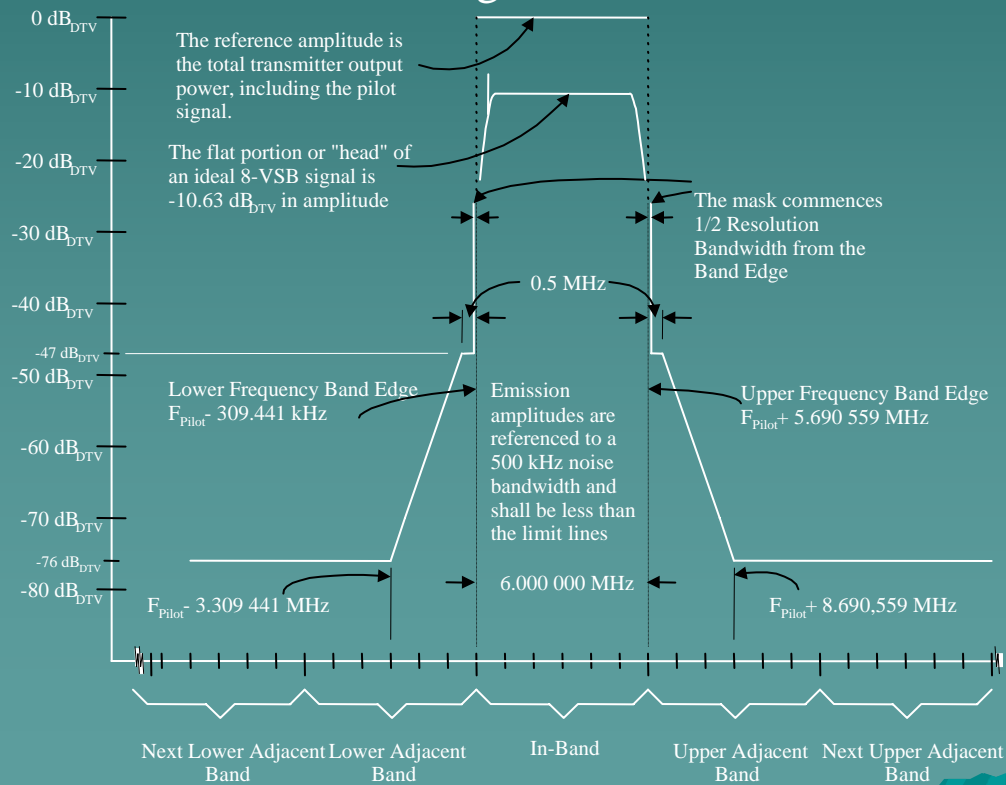

# DTV Transmission System Measurements

The End—Thank You *Very* Much